

Realization of Digital Filters

Discrete Time Systems: Overview

- The difference equation, the impulse response and the system function are equivalent characterization of the input/output relation of a LTI Discrete-time systems.
- LTI system can be modeled using :
 1. A Difference/Differential equation, $y(n) = x[n] + x[n-1] + \dots$
 2. Impulse Response, $h(n)$
 3. Transfer Function, $H(z)$
- The systems that are described by the difference equations, can be represented by structures consisting of an interconnection of the basic operations of addition, multiplication by a constant or signal multiplication, delay and advance.

- The Adder, Multiplier, Delay & Advance is shown below:

1. Adder :

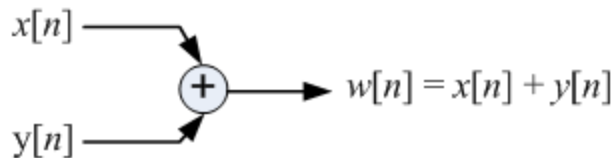

2. Multiplier :



Modulator:

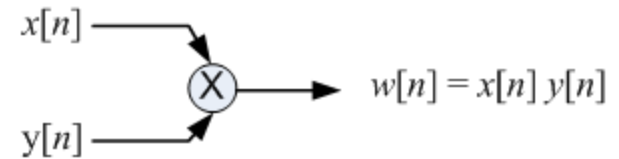

3. Delay :

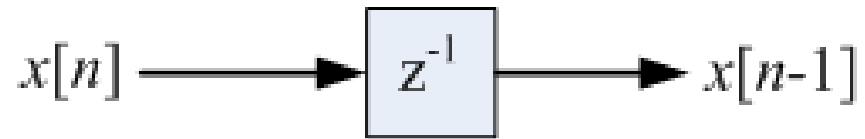

4. Advance :

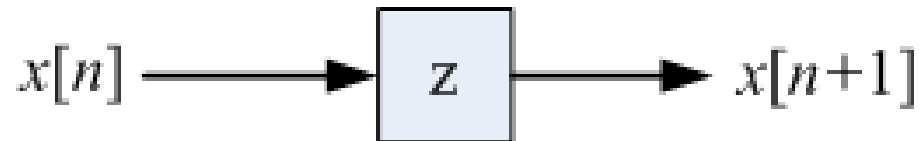

- Consider a first-order causal LTI IIR digital filter described by

$$y[n] = -d_1 y[n-1] + p_0 x[n] + p_1 x[n-1]$$

The block diagram representation is

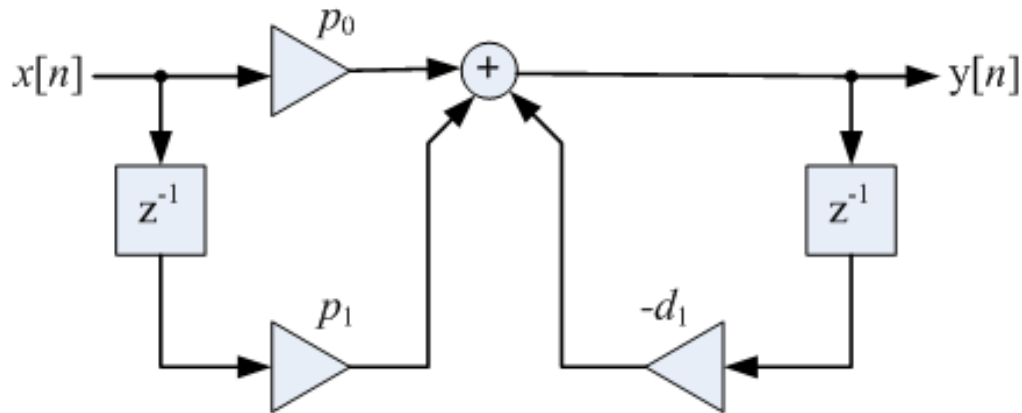

□ *Example 1 :*

Given an LTI system is described by the difference equation below:

$$y(n) - 0.25y(n-1) = 0.5x(n) + 0.5x(n-1)$$

Draw the block diagram representation

- The implementation of LTI system can be realized in terms of **Block Diagram** and **Signal Flow Graph**.
- The LTI system can be represented in 2 manner :
 - a. Block Diagram
 - b. Mathematical Model

- Example of Block diagram is shown below:

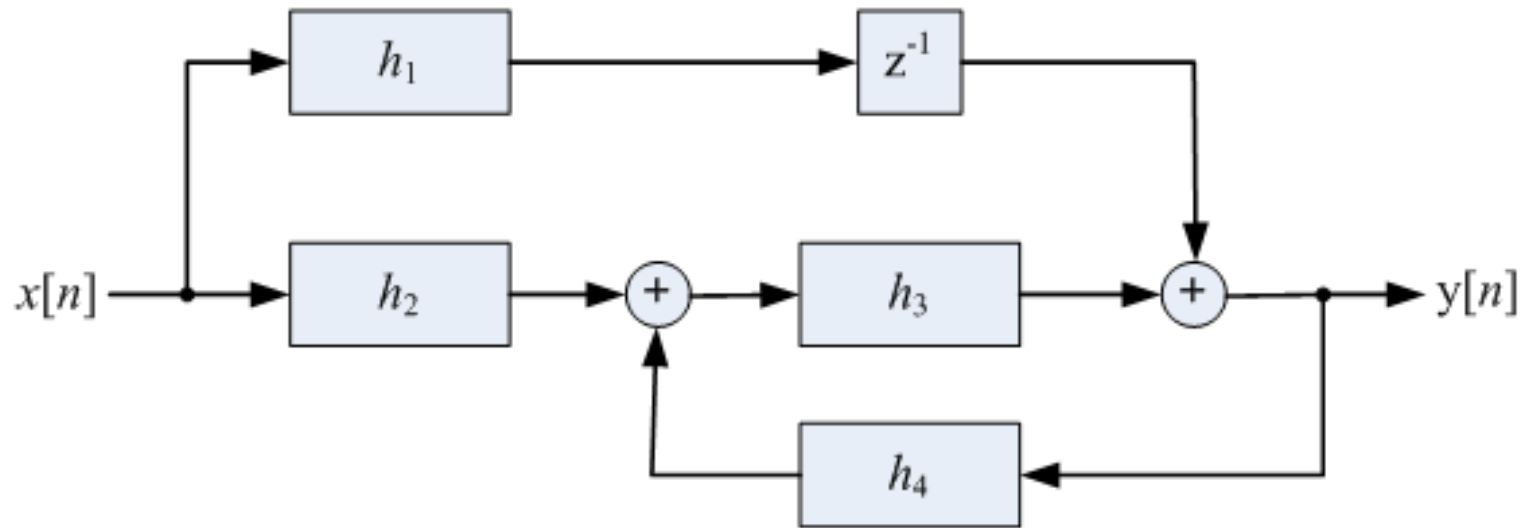

Block Diagrams

- Useful way to illustrate implementations
- Z-transform helps analysis:

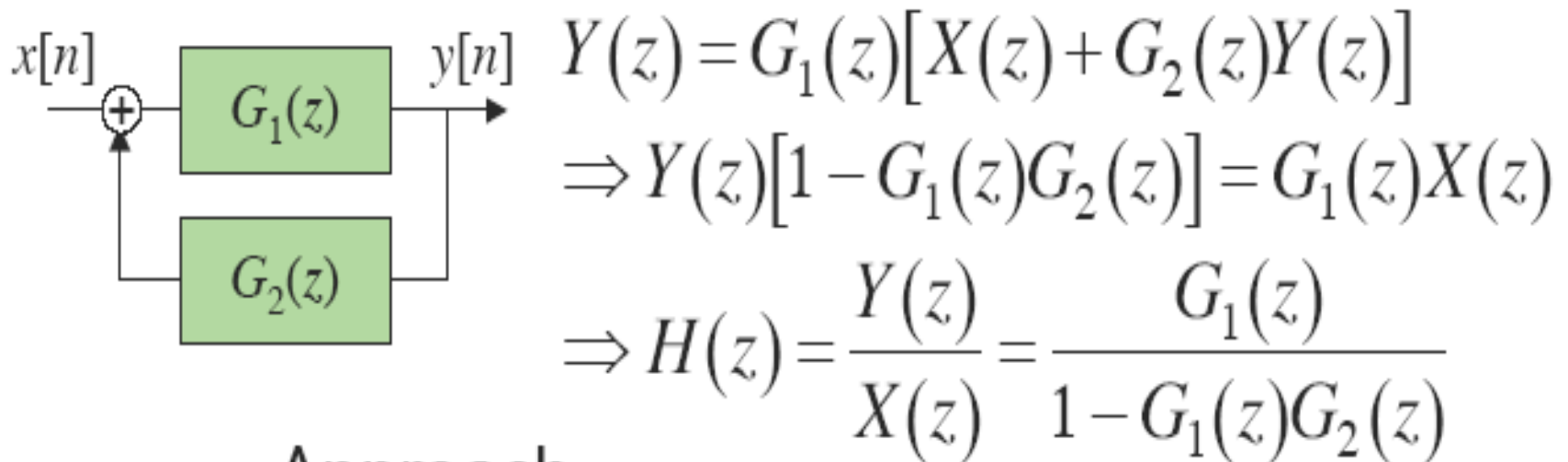

- Approach
 - Output of summers as dummy variables
 - Everything else is just multiplicative

Equivalent Structures

- Modifications to block diagrams that do not change the filter

- e.g. **Commutation** $H = AB = BA$

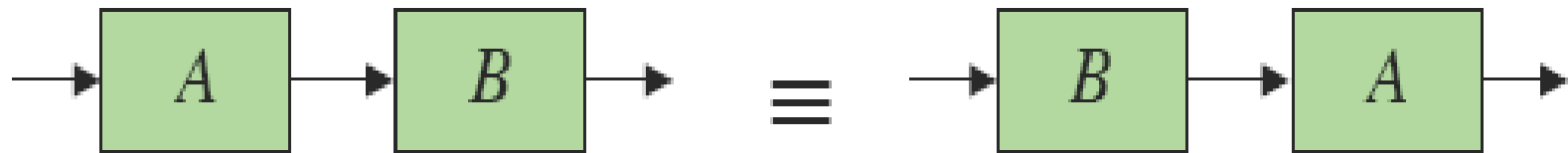

- **Factoring** $AB + CB = (A + C) \cdot B$

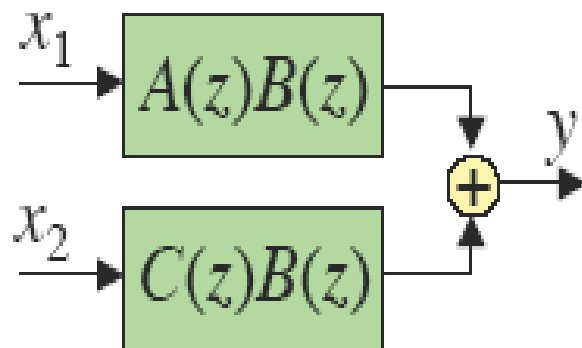

fewer blocks

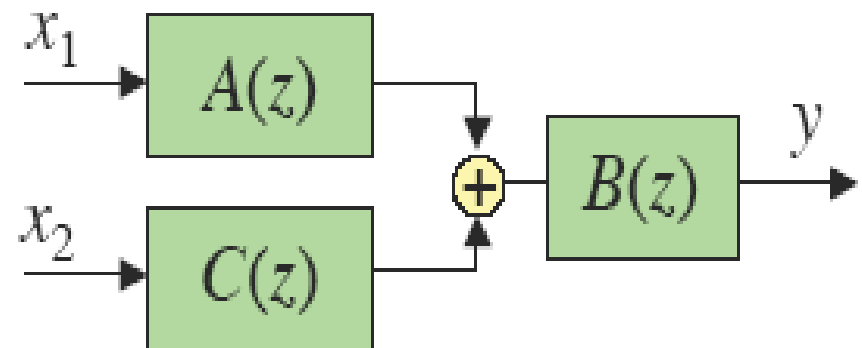

less computation



- The Transfer Function of LTI system can be connected in 2 ways :
 - a. Parallel Connection :

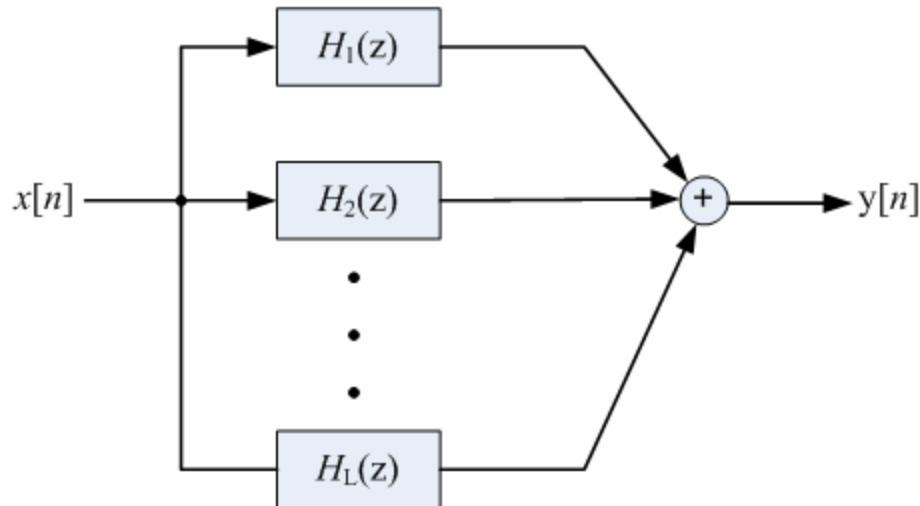

The overall transfer function,

$$H(z) = H_1(z) + H_2(z) + \dots + H_L(z)$$

- b. Cascade connection :

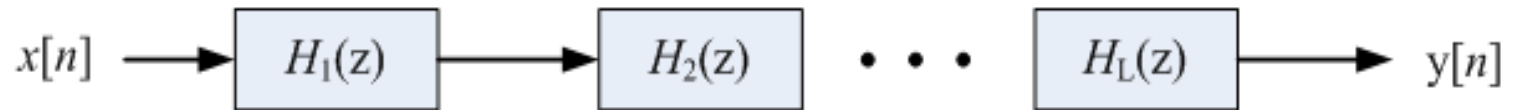

The overall transfer function :

$$H(z) = H_1(z) \cdot H_2(z) \cdot \dots \cdot H_L(z)$$

Each one of them can be implemented using any of the Direct Forms

- **Canonical**
 - number of delays in the block diagram representation is equal to the order of the difference equation
- **Non-canonical**
 - otherwise

FIR FILTER STRUCTURES

FIR FILTERS

- These are realized using only two Forms:
- (as it only has the Numerator part i.e. ALL ZERO SYSTEMS)
- 1. Direct Form 1 or Tapped delay Line or Transversal delay Line Filter.
- 2. Cascade form

FIR Filter Structures

- Direct form
 - An FIR filter of order N requires N + 1 multipliers, N adders and N delays.
 - An FIR filter of order 4

$$y[n] = h[0]x[n] + h[1]x[n-1] + h[2]x[n-2] + h[3]x[n-3] + h[4]x[n-4]$$

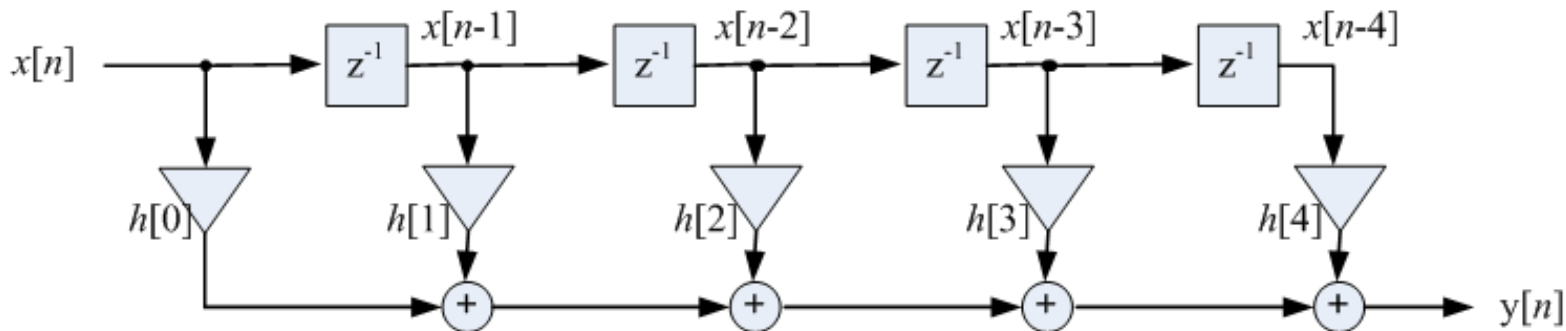

FIR Filter Structures

- Direct form “Tapped Delay Line”

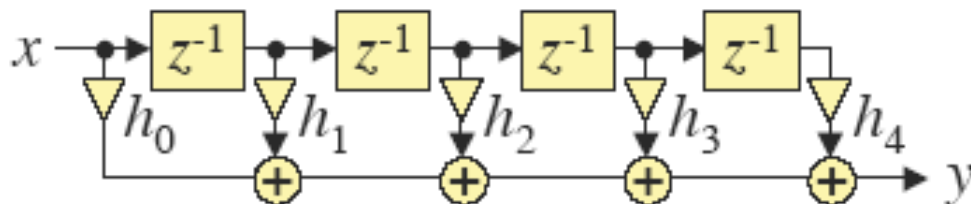

$$y[n] = h_0x[n] + h_1x[n-1] + \dots$$
$$= \sum_{k=0}^4 h_kx[n-k]$$

- Transpose

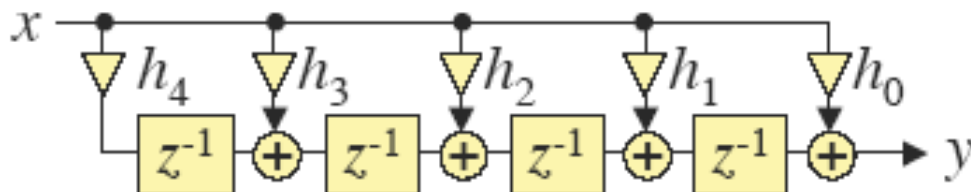

- Re-use delay line if several inputs x_i for single output y ?

- Cascade form

- Transfer function $H(z)$ of a causal FIR filter of order N

$$H(z) = \sum_{k=0}^N h[k]z^{-k}$$

- Factorized form

$$H(z) = h[0] \prod_{k=1}^k (1 + \beta_{1k}z^{-1} + \beta_{2k}z^{-2})$$

Where $k = N/2$ if N is even and $k = (N + 1)/2$ if N is odd, with $\beta_{2k} = 0$

Example...

- Determine the Direct Form & Cascade Form Realization for the transfer Function of an FIR Digital filter which is given by

$$H(z) = (1 - \frac{1}{4}Z^{-1} + \frac{3}{8}Z^{-2})(1 - \frac{1}{8}Z^{-1} - \frac{1}{2}Z^{-2})$$

Direct Form

- We Simply Expand the equation to get this form as

$$H(z) = 1 - \frac{3}{8}z^{-1} - \frac{3}{32}z^{-2} + \frac{5}{64}z^{-3} - \frac{3}{16}z^{-4}$$

This function can be realised in FIR direct form as depicted in figure 8.72.

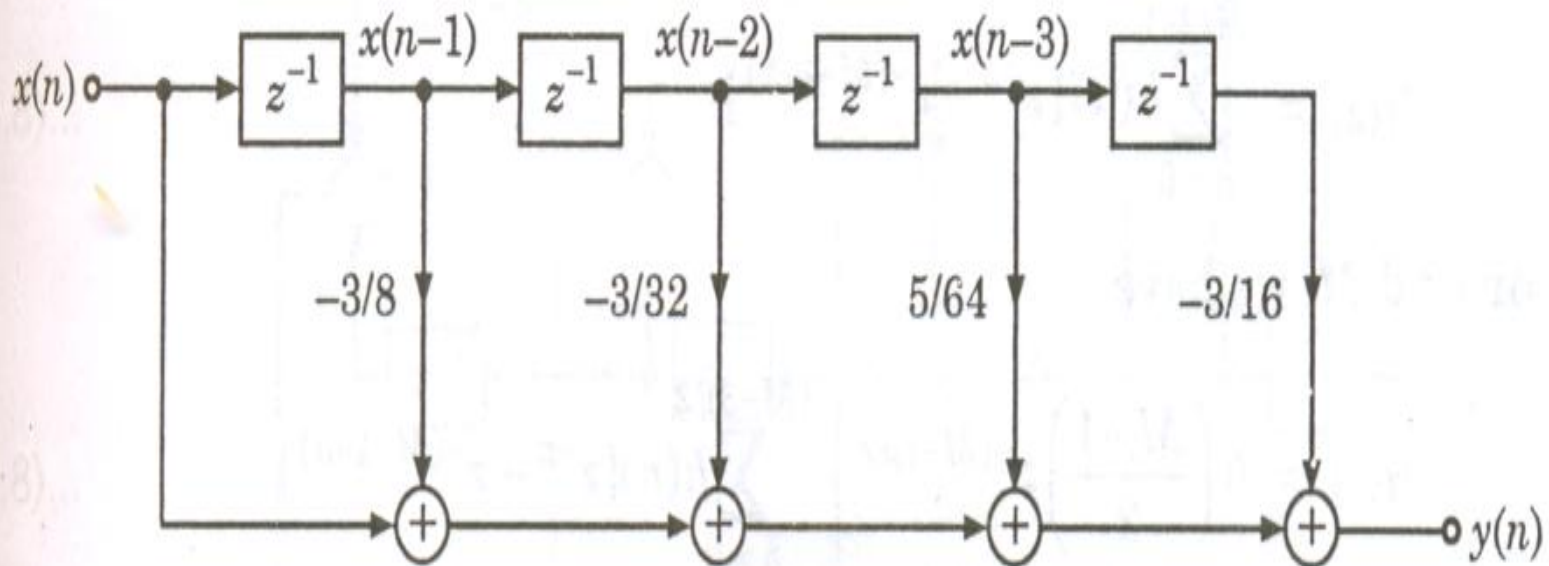

Fig. 8.72 Direct form realization

Cascade Form

- $H(z) = H_1(z) * H_2(z)$ & hence

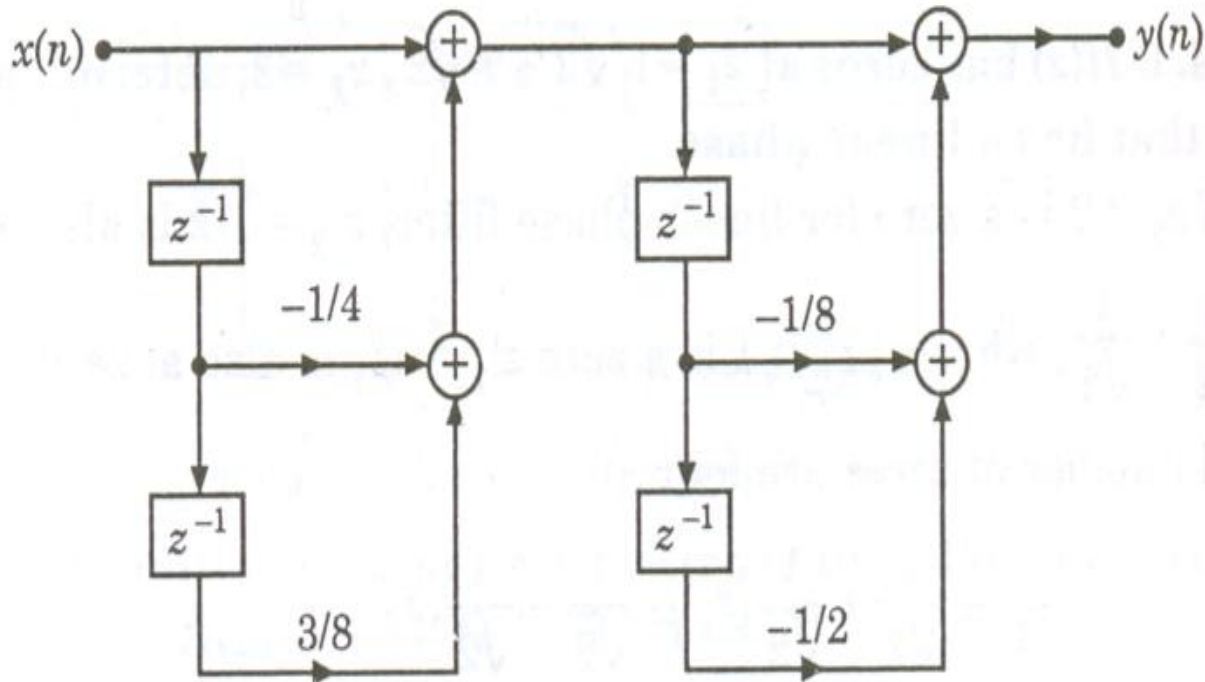

Fig. 9.79 Cascade form realization

Equivalent Structures

■ Transpose

- reverse paths
- adders \leftrightarrow nodes
- input \leftrightarrow output

$$\begin{aligned} Y &= b_1 X + b_2 z^{-1} X + b_3 z^{-2} X \\ &= b_1 X + z^{-1} (b_2 X + z^{-1} b_3 X) \end{aligned}$$

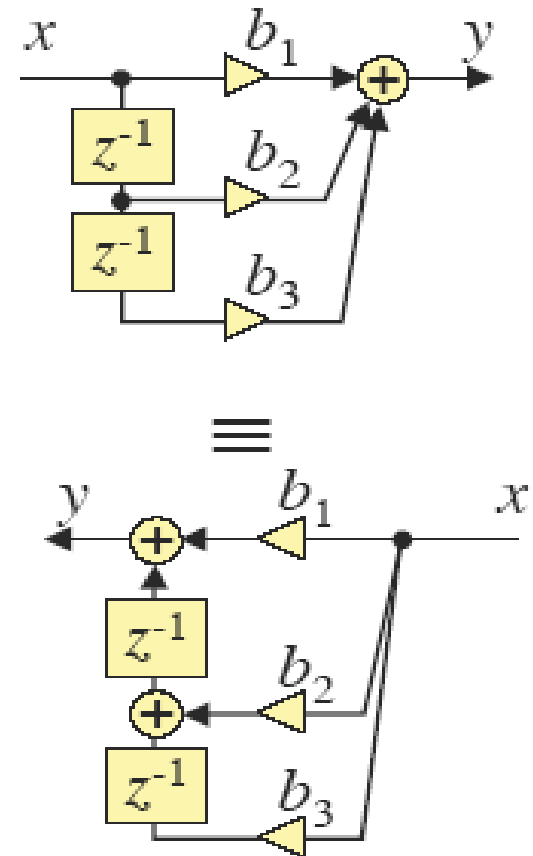

IIR FILTER STRUCTURES

- IIR system/filter can be realized in several structures:

1. DIRECT FORM I

2. DIRECT FORM II (CANONIC)

3. CASCADE FORM

4. PARALLEL FORM

IIR System Function

→

$$H(z) = \frac{Y(z)}{S(z)} = \frac{\sum_{k=0}^{M-1} B_k z^{-k}}{1 + \sum_{k=1}^{N-1} A_k z^{-k}}$$

where M and N are integer numbers.

Bifurcation of $H(z)$ into $H_1(z)$ & $H_2(z)$

247

$$H(z) = \frac{\sum_{k=0}^{M-1} B_k z^{-k}}{1 + \sum_{k=1}^{N-1} A_k z^{-k}} = H_1(z) \cdot H_2(z) \quad \dots(7.3)$$

$$H_1(z) = \sum_{k=0}^{M-1} B_k z^{-k} \quad \dots(7.4)$$

$$\begin{aligned} H_2(z) &= \frac{1}{1 + \sum_{k=1}^{N-1} A_k z^{-k}} \\ &= \left[1 + \sum_{k=1}^N A_k z^{-k} \right]^{-1} \\ &= 1 - \sum_{k=1}^N A_k z^{-k} = 1 + \sum_{k=1}^N (-A_k) z^{-k} \quad \dots(7.5) \end{aligned}$$

Block Diagram of Direct Form I & II

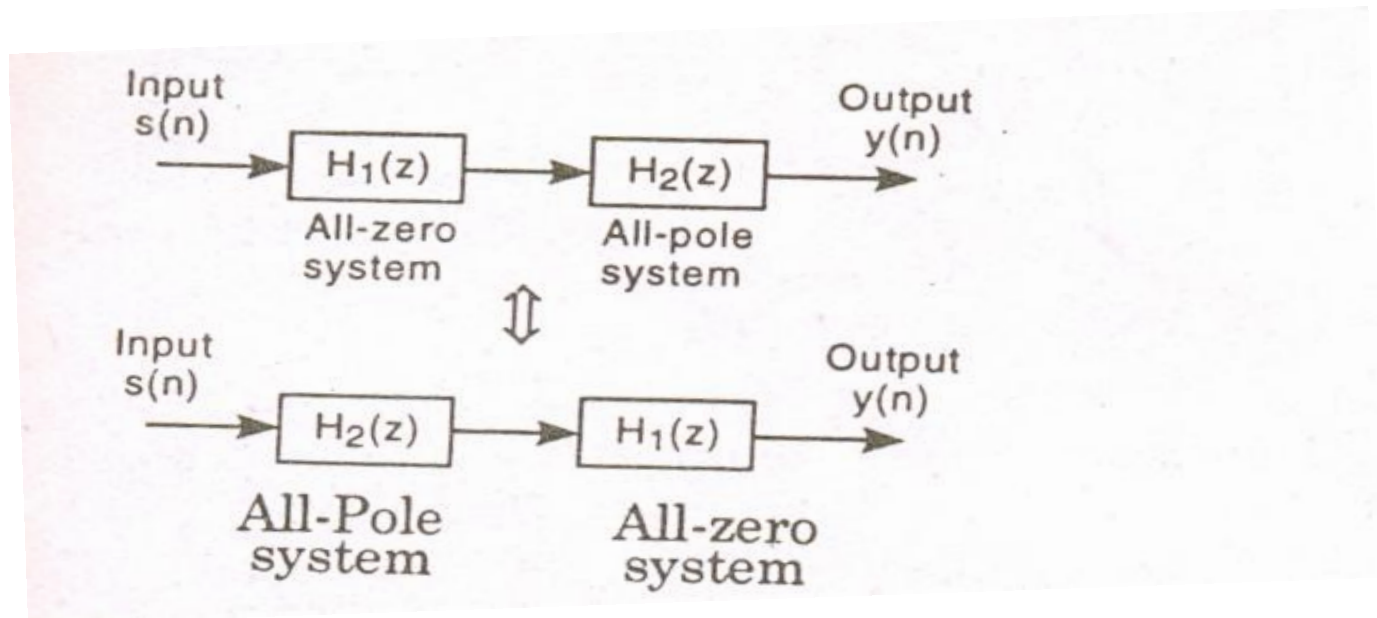

IIR Filter Structures

- IIR: numerator + denominator

$$H(z) = \frac{p_0 + p_1z^{-1} + p_2z^{-2} + \dots}{1 + d_1z^{-1} + d_2z^{-2} + \dots}$$

$$= P(z) \cdot \frac{1}{D(z)}$$

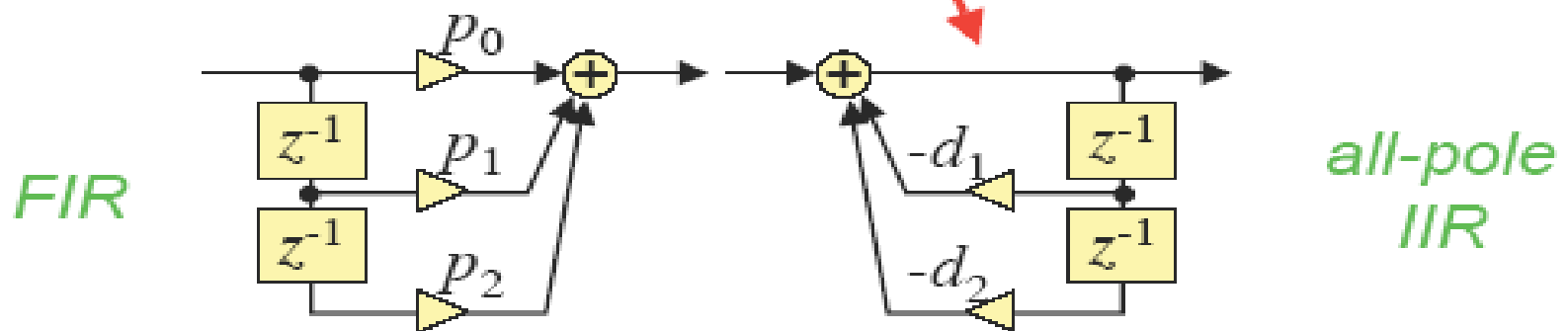

IIR Filter Structures

- Hence, **Direct form I**

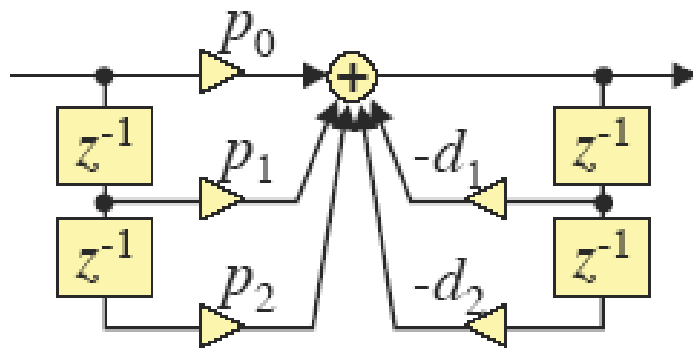

- Commutation \rightarrow **Direct form II (DF2)**

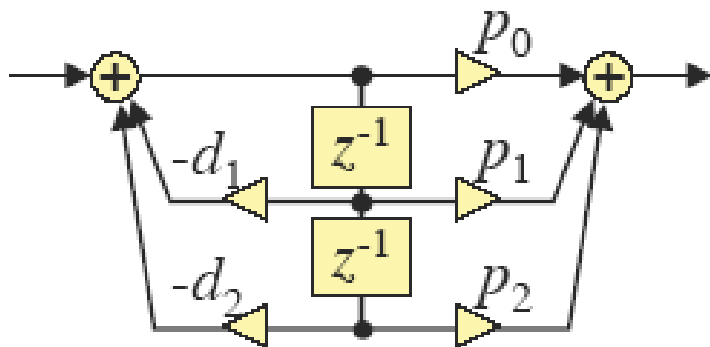

- *same signal*
 \therefore *delay lines merge*
- *“canonical”*
= min. memory usage

Direct Form I Realization



(a)

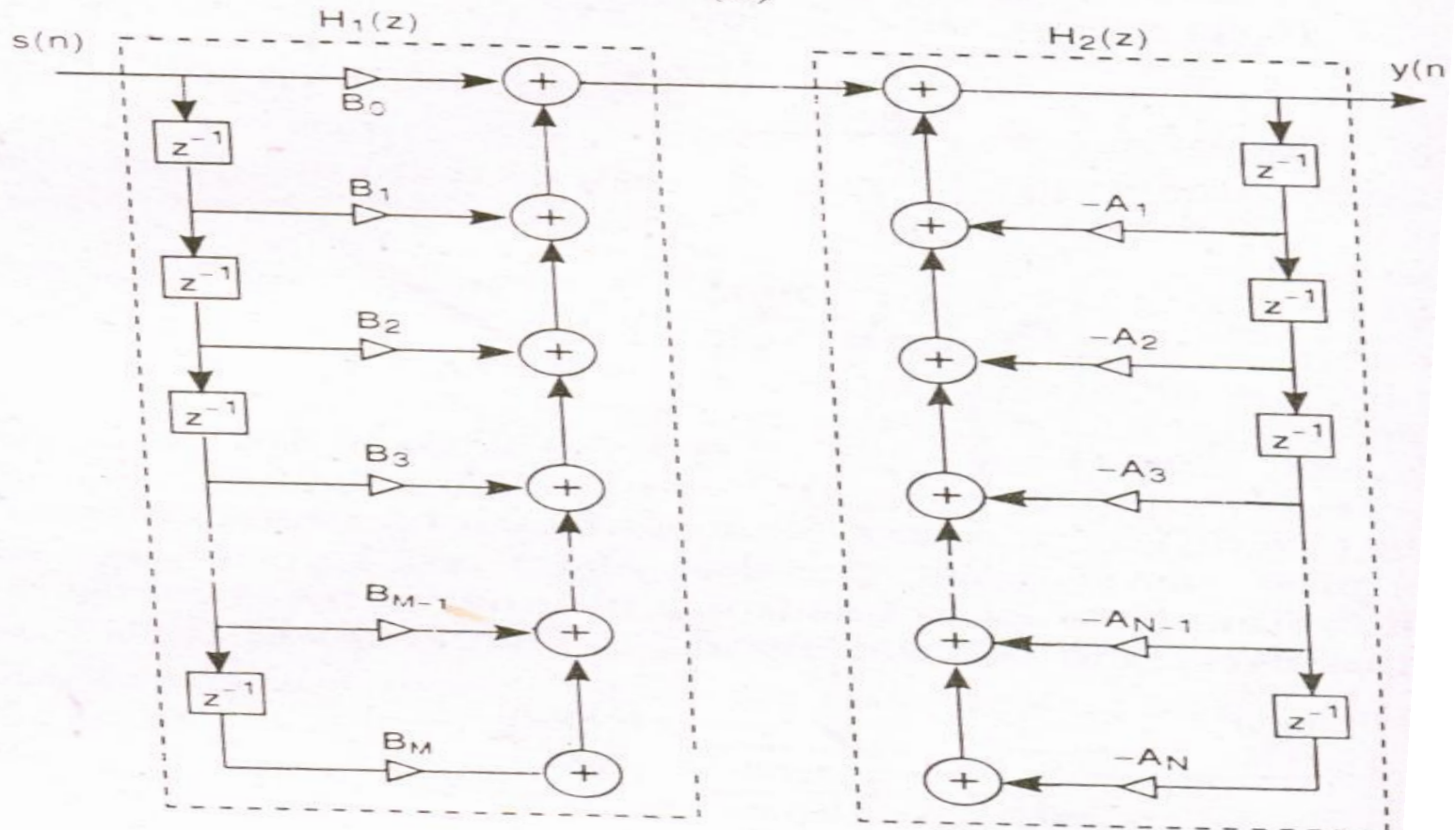

(b)

Direct Form II Realization

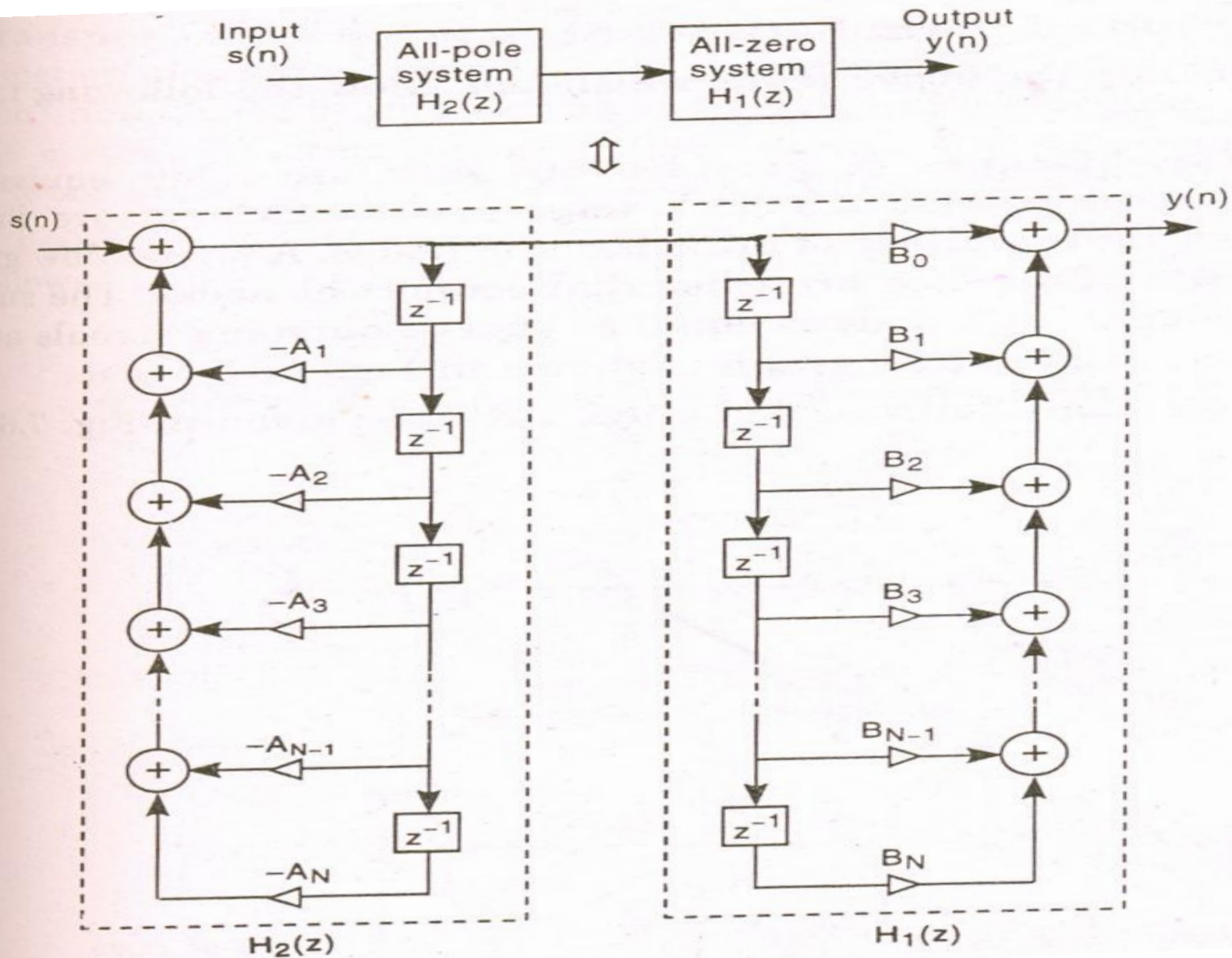

Canonic Direct Form II Realization

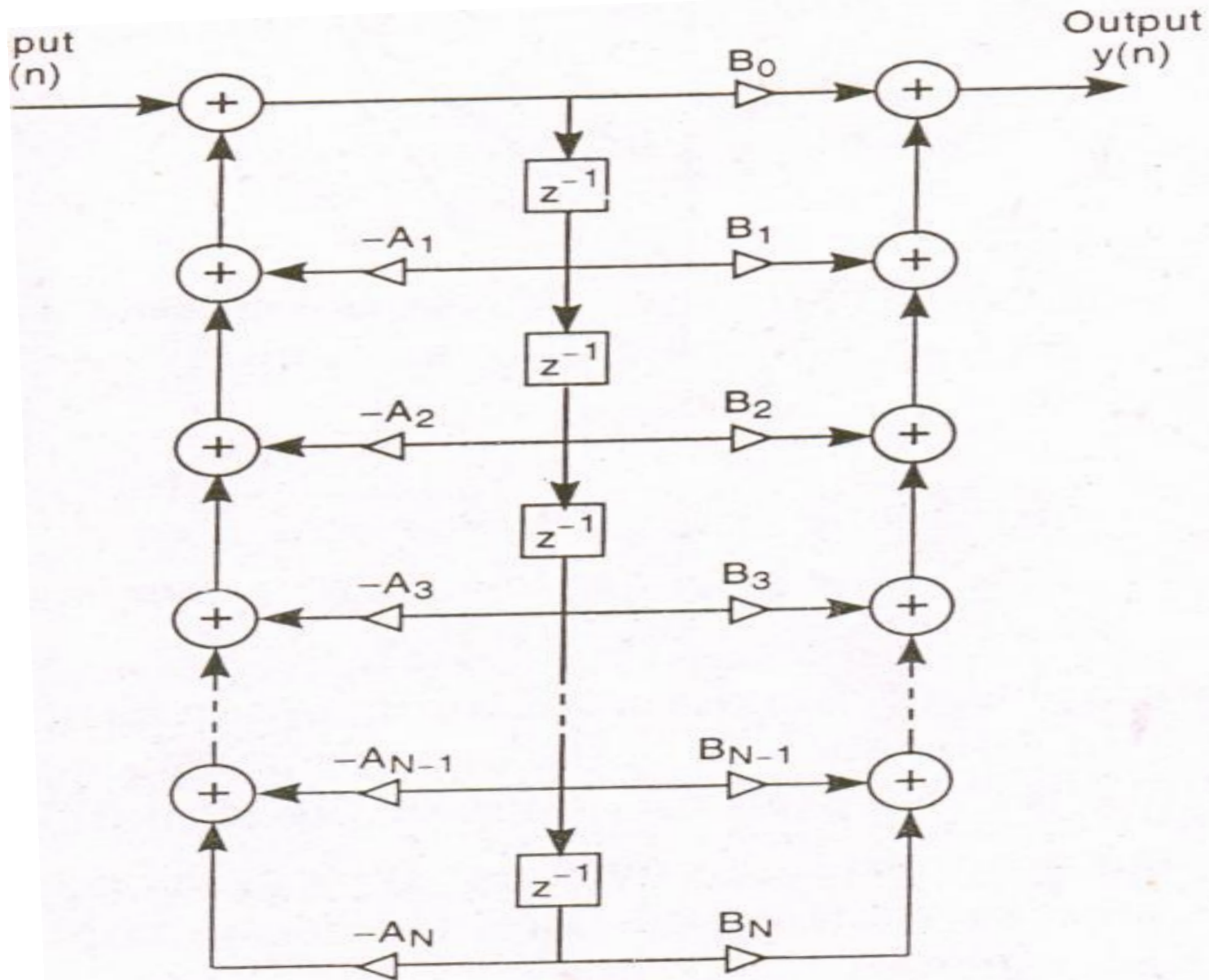

Fig. 7.5 Direct Form II Realization

Parallel Form Realization

$$H_k(z) = \frac{B_{k0} + B_{k1}z^{-1}}{1 + A_{k1}z^{-1} + A_{k2}z^{-2}} \quad \dots(7.9)$$

Coefficients B_{ki} and A_{ki} real-valued system parameters.

Parallel form network structures are shown in Fig. 7.9 and Fig. 7.10.

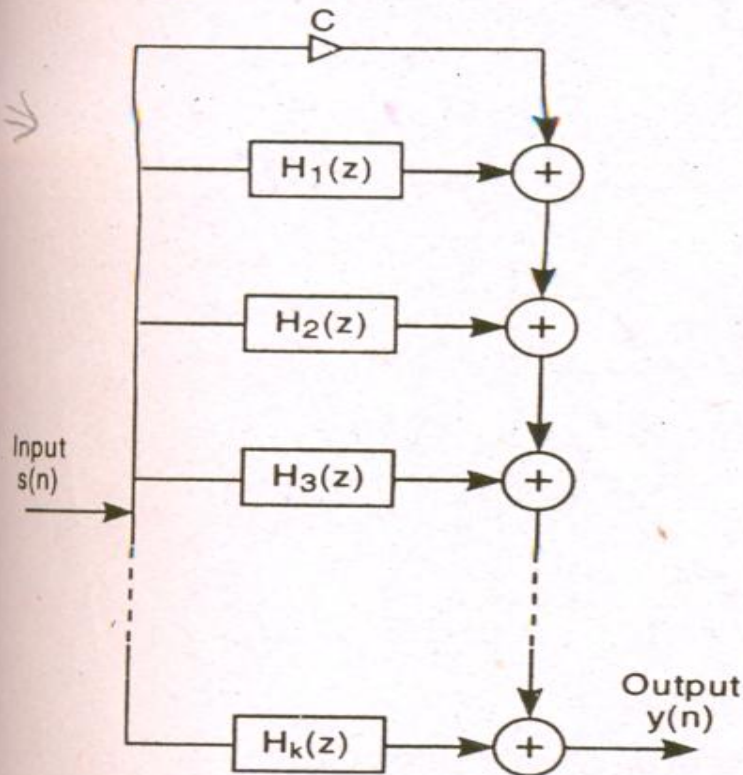

Fig. 7.9 Paralled-form network structure of IIR system.

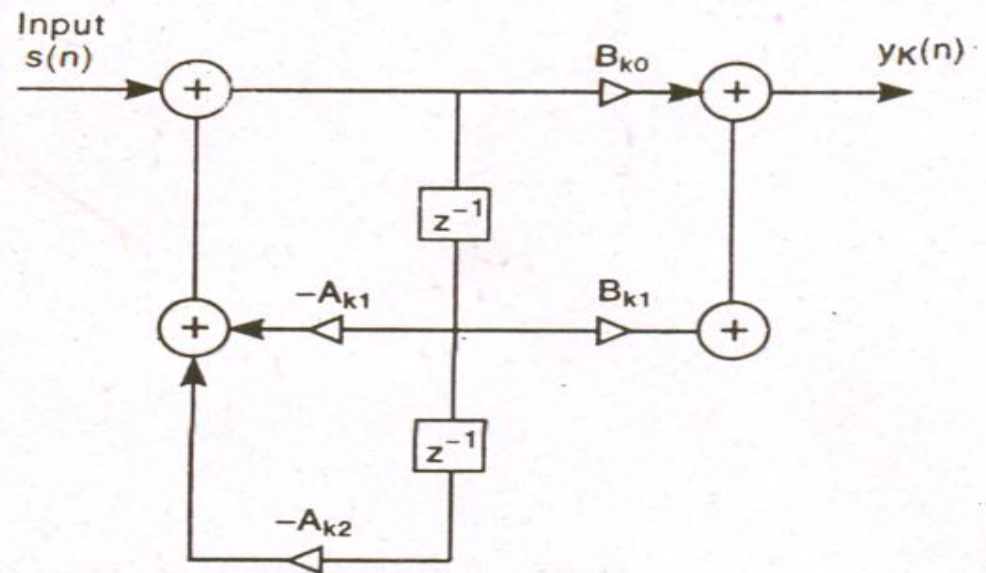

Fig. 7.10 Structure of IInd order section in a parallel-form network structure realization.

Example..

Example 7.2 Sketch the direct form-I, direct form-II, cascade and parallel-form network structures for the system characterized by following difference equations.

$$y(n) = \frac{3}{4}y(n-1) - \frac{1}{8}y(n-2) + s(n) + \frac{1}{3}s(n-1)$$

Direct Form I

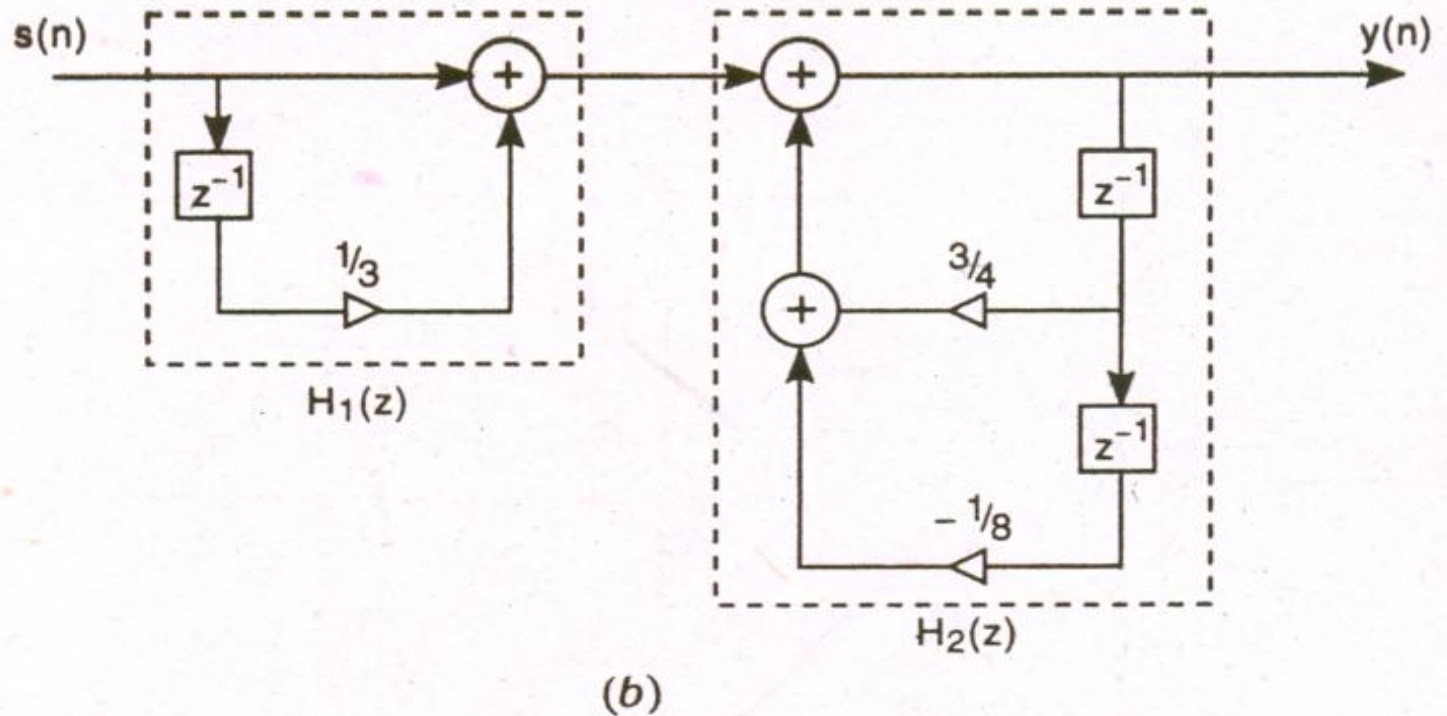
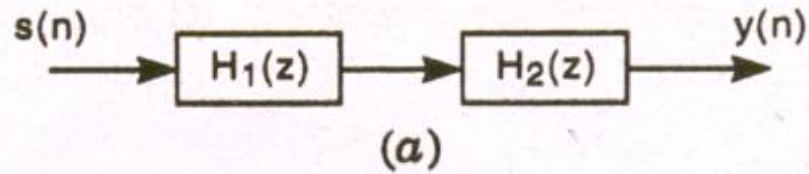

(a) Block diagram of direct form-I of above problem.

(b) Direct form-I, network structure of above filter.

Direct Form II & Cascade Form

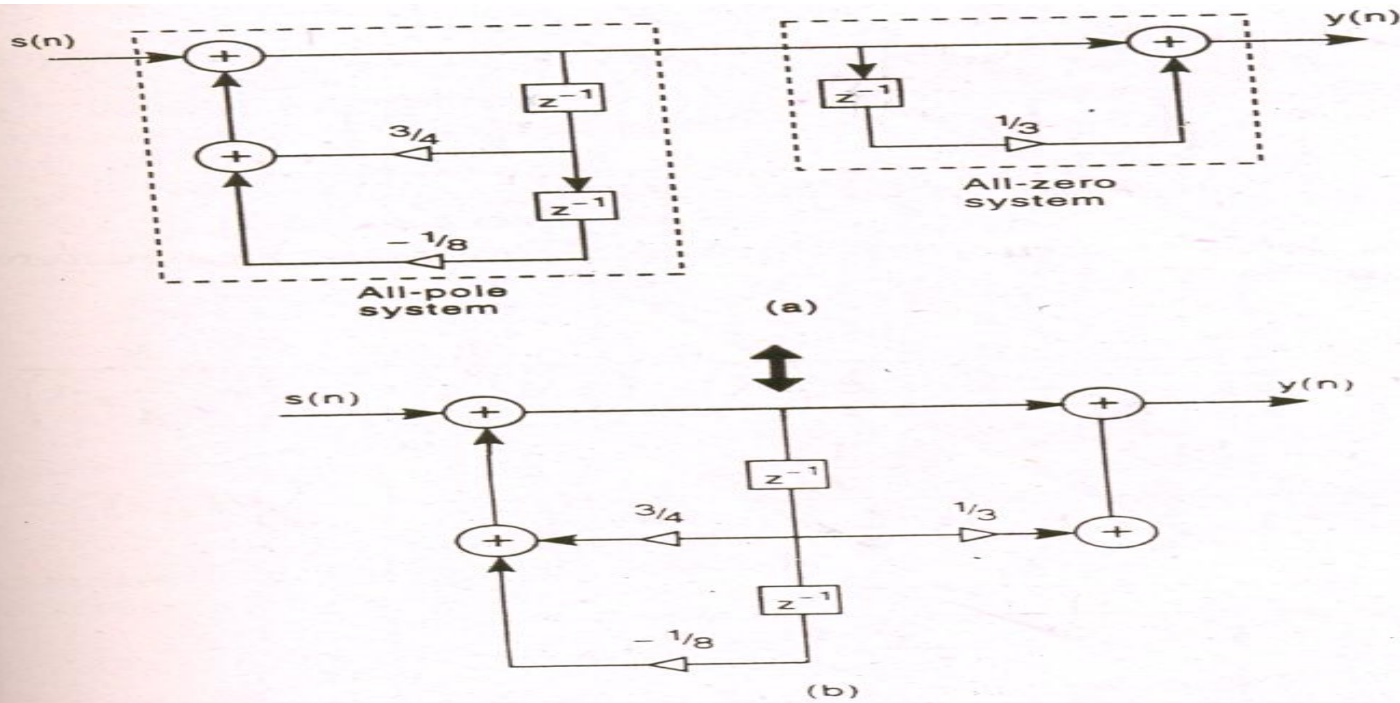

Fig. 7.12 Direct form-II realization of above filter.

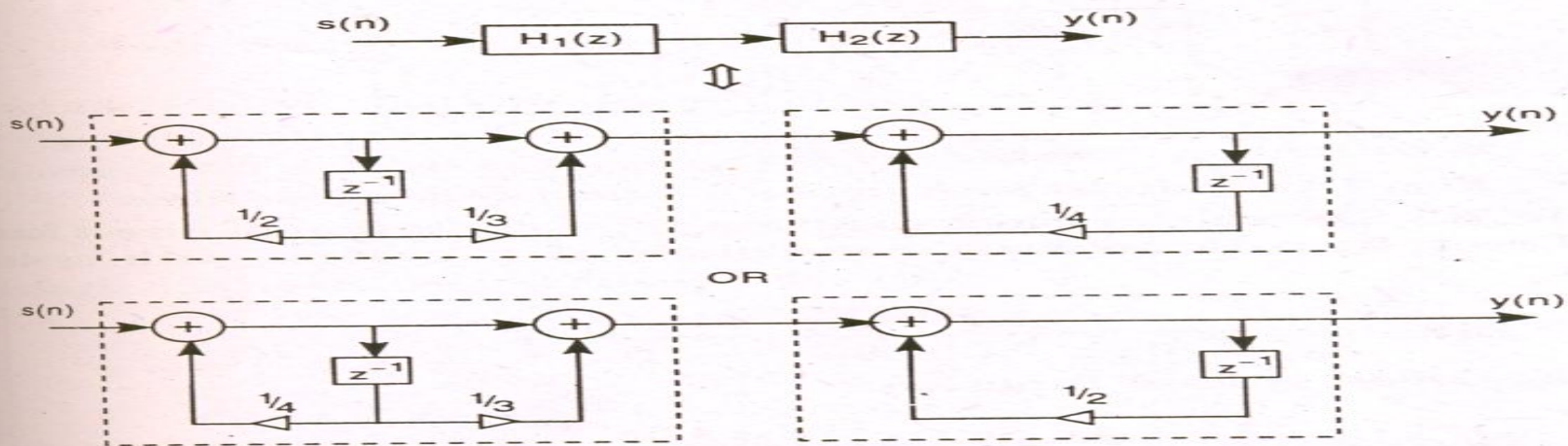

Fig. 7.13 Cascade-form network structure of above filter.

Parallel Form

- To get this we use PFE method :
- $H(z) = Y(z)/X(z)$
- Giving us $A_1 = -7/3$ & $A_2 = 10/3$ so implementing it we have -----

Parallel Form

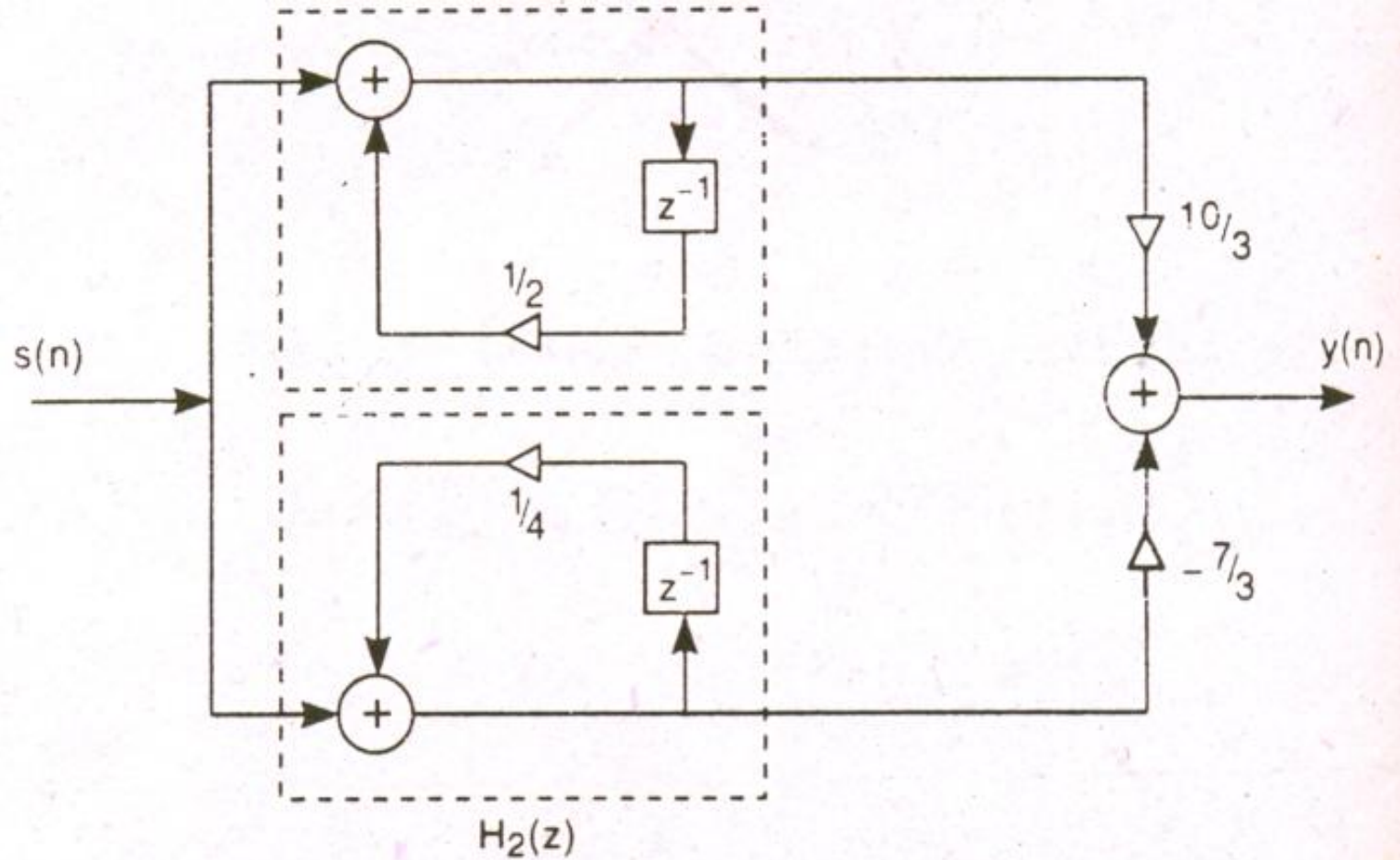

Fig. 7.14 Parallel form network structure of above filter.

- Direct Form I

- Consider a third order IIR described by transfer function

$$H(z) = \frac{P(z)}{D(z)} = \frac{p_0 + p_1z^{-1} + p_3z^{-3}}{1 + d_1z^{-1} + d_3z^{-3}}$$

- Implement as a cascade of two filter section



Where

$$H_1(z) = \frac{W(z)}{X(z)} = P(z) = p_0 + p_1z^{-1} + p_2z^{-2} + p_3z^{-3}$$

and

$$H_2(z) = \frac{Y(z)}{W(z)} = \frac{1}{D(z)} = \frac{1}{1 + d_1z^{-1} + d_2z^{-2} + d_3z^{-3}}$$

- Resulting in realization indicated below

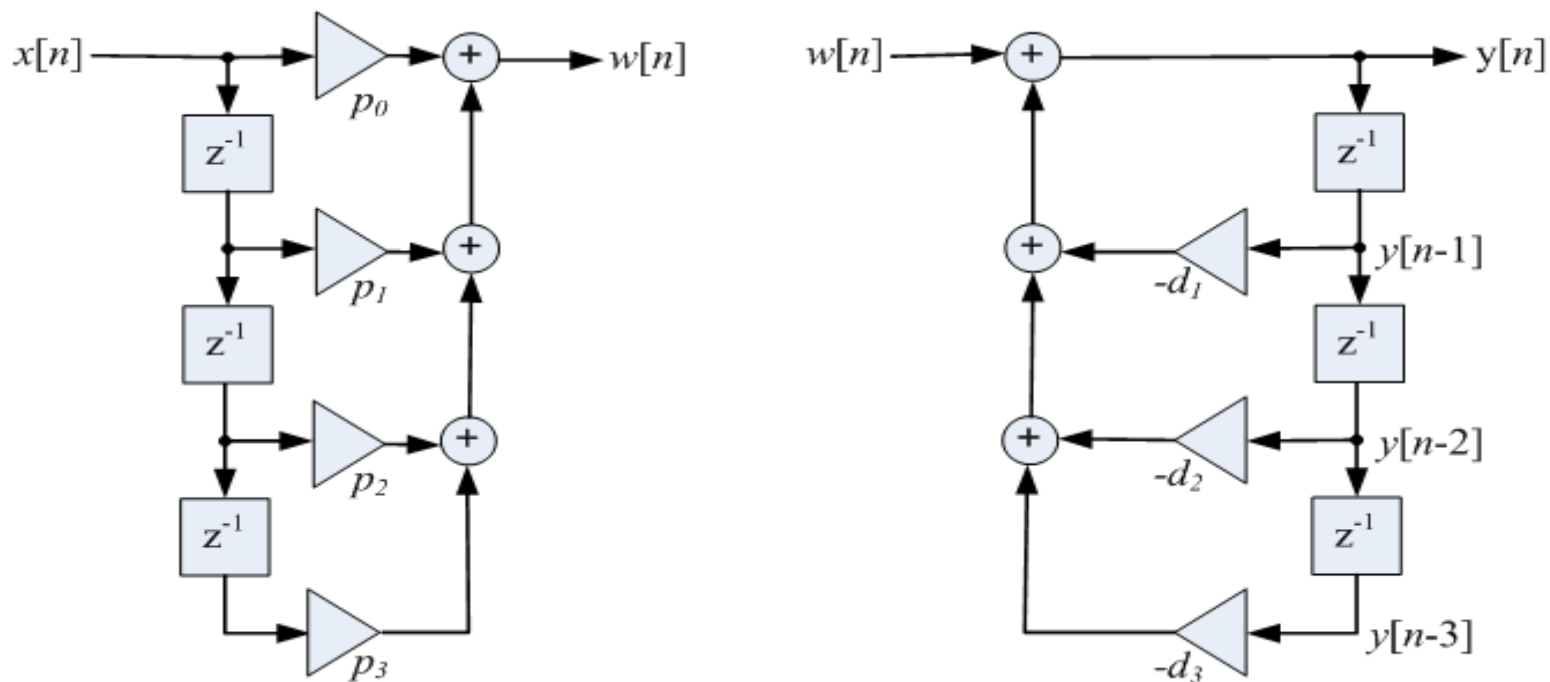

- Direct Form I

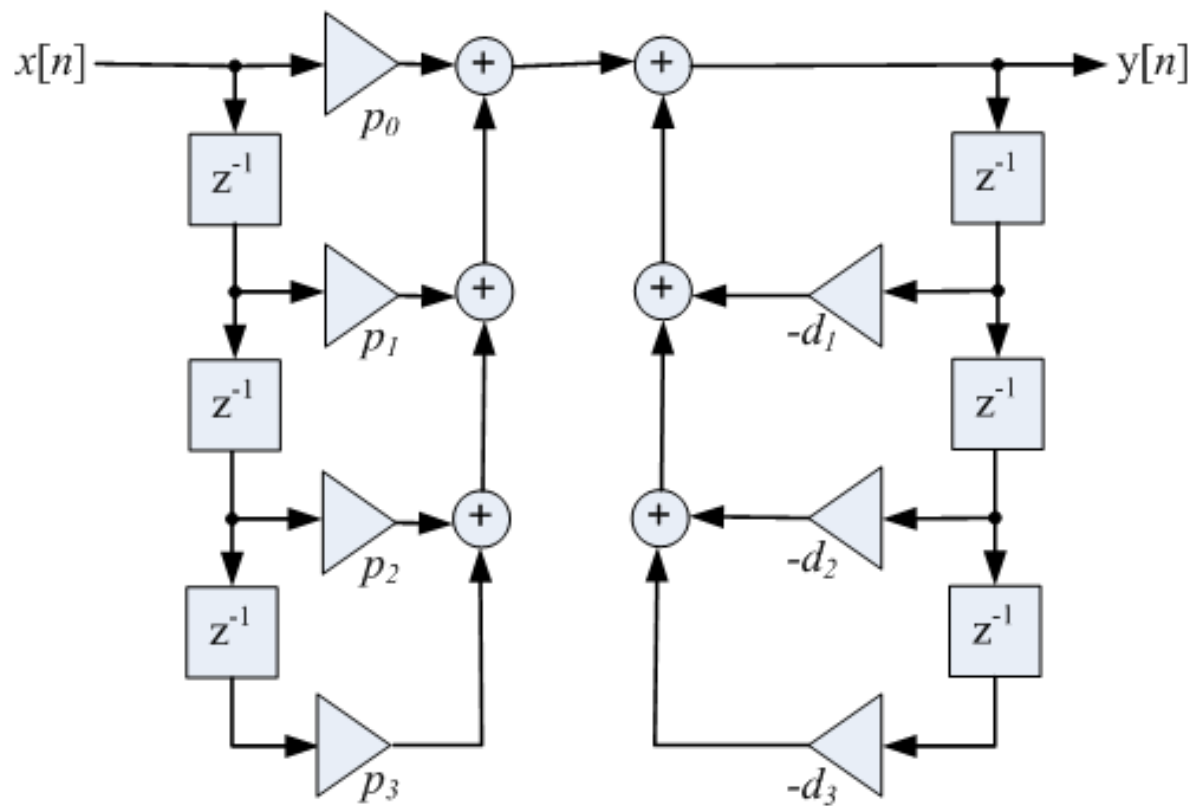

- Direct Form II (Canonic)

- The two top delays can be shared

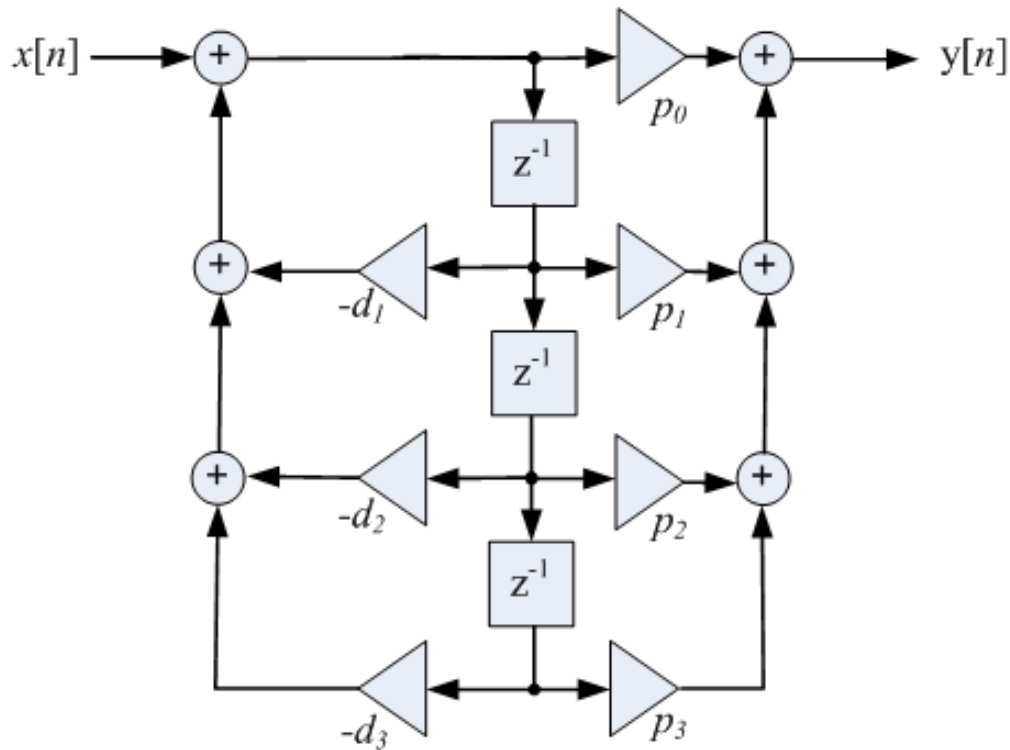

- Cascade Form

$$H(z) = p_0 \prod_k \left(\frac{1 + \beta_{1k}z^{-1} + \beta_{2k}z^{-2}}{1 + \alpha_{1k}z^{-1} + \alpha_{2k}z^{-2}} \right)$$

- A third order transfer function

$$H(z) = p_0 \left(\frac{1 + \beta_{11}z^{-1}}{1 + \alpha_{11}z^{-1}} \right) \left(\frac{1 + \beta_{12}z^{-1} + \beta_{22}z^{-2}}{1 + \alpha_{12}z^{-1} + \alpha_{22}z^{-1}} \right)$$

- Cascade Form

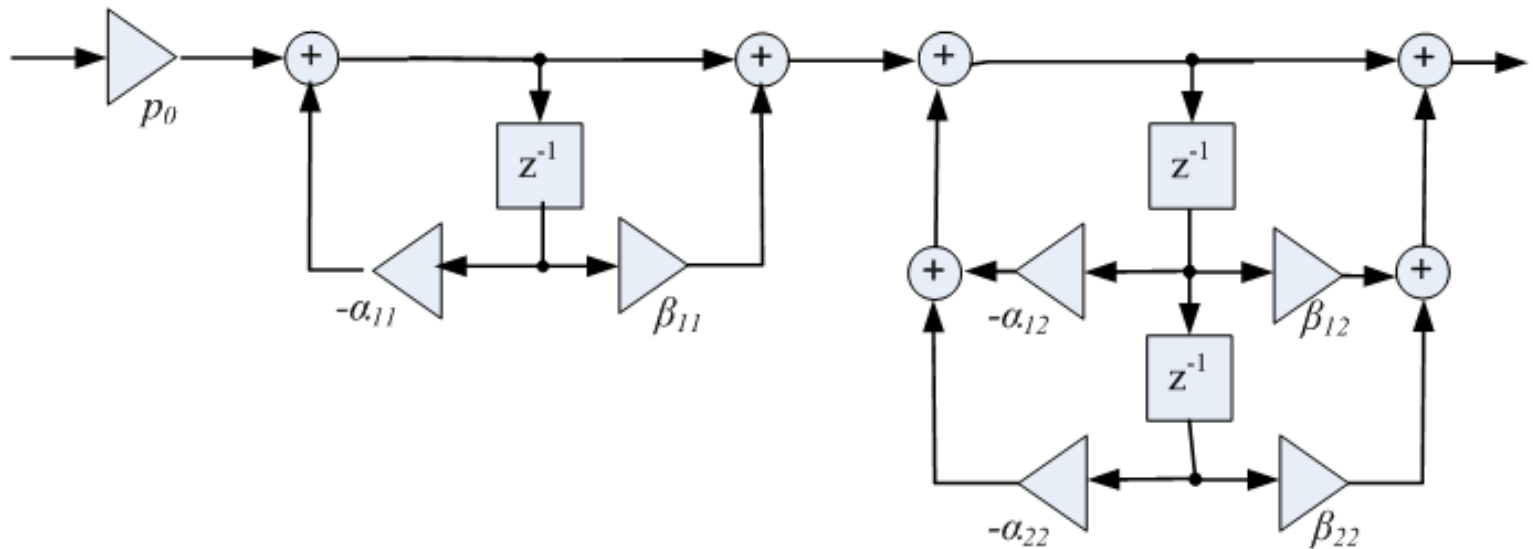

- Parallel Form: Use Partial Fraction Expansion Form to realize them

$$H(z) = \gamma_0 + \sum_k \left(\frac{\gamma_{0k} + \gamma_{1k} z^{-1}}{1 + \alpha_{1k} z^{-1} + \alpha_{2k} z^{-2}} \right)$$

- Parallel Form: used in High Speed Filtering applications(as operated parallely)

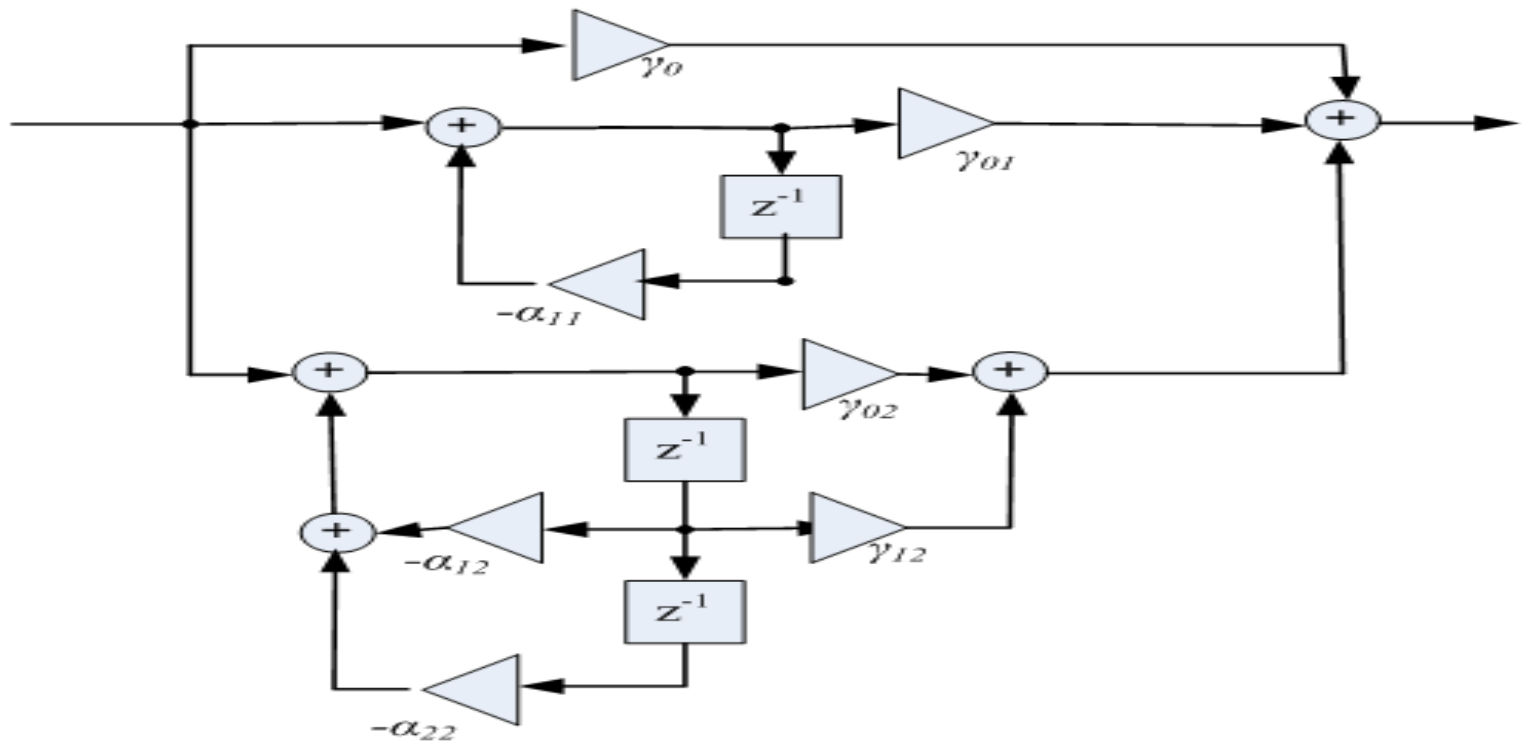

Parallel IIR Structures

- Can express $H(z)$ as sum of terms (**IZT**)

$$H(z) = \text{consts} + \sum_{\ell=1}^N \frac{\rho_{\ell}}{1 - \lambda_{\ell} z^{-1}} \quad \rho_{\ell} = (1 - \lambda_{\ell} z^{-1}) F(z) \Big|_{z=\lambda_{\ell}}$$

- Or, second-order terms:

$$H(z) = \gamma_0 + \sum_k \frac{\gamma_{0k} + \gamma_{1k} z^{-1}}{1 + \alpha_{1k} z^{-1} + \alpha_{2k} z^{-2}}$$

- Suggests **parallel** realization...

Parallel IIR Structures

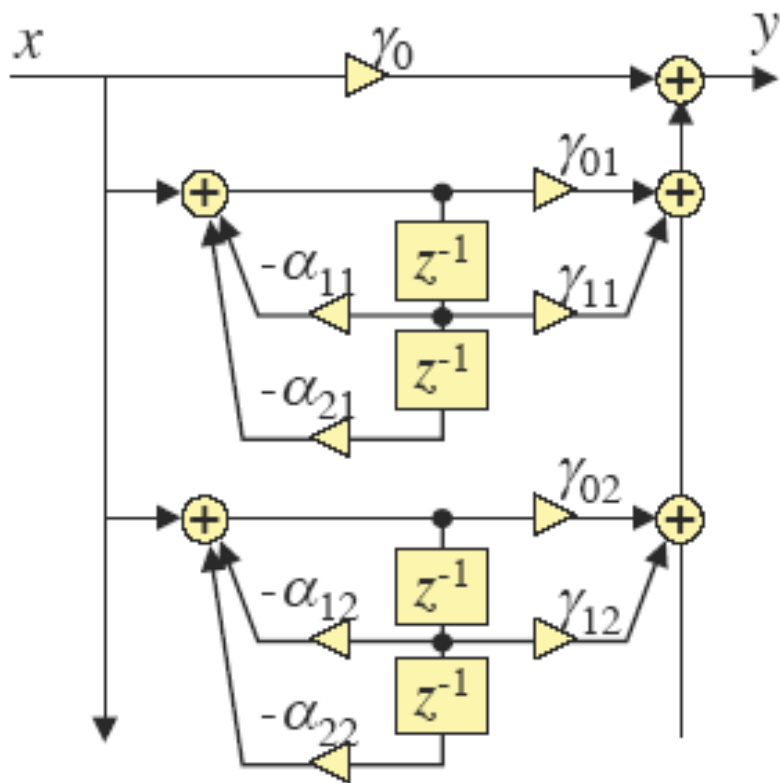

- Sum terms become parallel paths
- **Poles** of each SOS are from full TF
- System **zeros** arise from output sum
- Why do this?
 - stability/sensitivity
 - reuse common terms